

Canon

BU-47H/BU-51H

Canon Remote Control Pan-Tilt System



INNOVATION
In TV Optics Since 1958

HD

BU-47H

Outdoor Remote Control Pan-Tilt System



As the worldwide transition to HD (high definition) imaging continues to accelerate, many video content creators including broadcasters, cable networks and business/industrial entities are seeking cost-effective, turnkey, remotely-controllable Pan-Tilt-Zoom (PTZ) HD camera systems to extend creative flexibilities. To meet these diverse needs, Canon has harnessed multiple unique technologies and experience in HD optics and digital cameras, robotics, and control software, to produce a cost-effective, integrated HD lens-camera PTZ product offering exceptional HD picture quality. The BU-47H is a rugged yet elegant outdoor PTZ system-following a legacy of decades of Canon expertise in designing such systems. A sister product, the BU-51H, has a design tailored for exacting indoor applications.



Outdoor Event Broadcast



Weather POV



Traffic POV



Outdoor Monitoring



Tourism Promotion

BU-47H Features

HIGH QUALITY HDTV/SDTV VIDEO IMAGES

The BU-47H have a 1/3 inch 3CMOS camera with 2,370,000 pixels per CMOS. It offers exceptional video quality for broadcasting, event coverage and high quality surveillance, among others.

HIGH OPTICAL PERFORMANCE AND IMAGE STABILIZATION

The 3 CMOS HD camera combines a 18X Optical Zoom HD lens (4.1-73.8mm, 6.2-111mm with 1.5X Digital Extender) with Auto Focus and Image Stabilization, providing exceptional HD video images with enhanced operational flexibilities.

WEATHERPROOF

The BU-47H is an extremely sturdy, dustproof/waterproof pan-tilt system with an IP45 enclosure rating. Well suited for outdoor operation, the BU-47H also incorporates a built-in wiper.

WIDE PAN-TILT COVERAGE

The BU-47H can pan through $\pm 340^\circ$ and tilt $+30^\circ \sim -50^\circ$ in highly precise and smoothly choreographed movements specifically designed to address multiple applications.

NON-PROPRIETARY PROTOCOL

As the control protocol is non-proprietary and open to the public, a user or system integrator can provide their own control system or contract with a third party provider.

VARIETY OF OUTPUTS

The camera outputs an uncompressed HD-SDI (or SD-SDI) signal. The HD-SDI signal and an SD Composite signal (NTSC or PAL)* can be output simultaneously. The SD signal can be used for monitoring. In addition, the BU-47H features GENLOCK for video synchronization.

*Please request NTSC or PAL format at time of purchase

SLEEK DESIGN

The elegant design makes the BU-47H blend in very naturally with buildings and other city landscapes.



BU-47H System Configuration Examples

For Short Distance Control

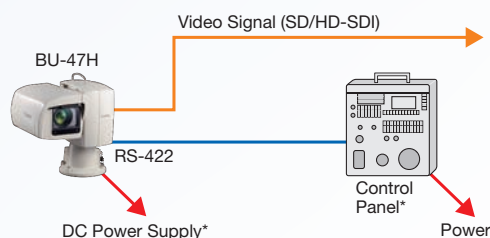

For Long Distance Control

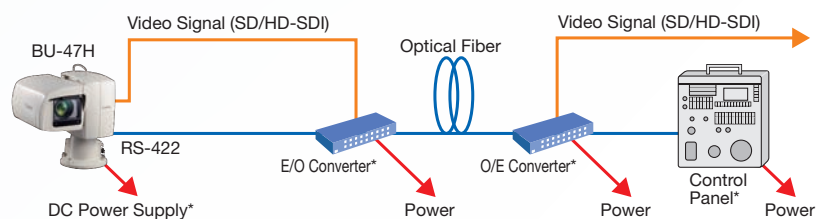

*Optional items to be supplied from third party vendors.



BU-51H

Indoor Remote Control Pan-Tilt System

The BU-51H is a highly versatile turnkey HD Pan-Tilt-Zoom camera system intended to address a wide range of indoor applications. It features a pan-tilt head, a built-in 20X zoom lens, and a 3 CCD HD video camera all housed in an elegant design. The system offers extensive control of the pan-tilt head, lens functions, and key camera CCU adjustments. The system was specifically designed to achieve an excellent HD cost-performance optimization.



Education



Indoor Event/IMAG



House of Worship



Newsroom/Studio Camera



Video Conferencing

BU-51H Features

HIGH QUALITY HDTV/SDTV VIDEO IMAGES

The BU-51H have a 1/3 inch 3CCD HD camera with 1,670,000 pixels per CCD. It offers exceptional video quality for broadcasting, event coverage and high quality surveillance, among others.

HIGH OPTICAL PERFORMANCE AND IMAGE STABILIZATION

The 3 CCD HD camera combines a 20X Optical Zoom HD lens (4.5-90mm, 9-180mm with 2X Digital Extender) with Auto Focus and Image Stabilization, providing exceptional HD video images with enhanced operational flexibilities.

EXTREMELY QUIET

The BU-51H is an extremely quiet Pan-Tilt system featuring a maximum noise level of NC30. Thus it is well suited for operation in a very quiet environment such as a conference, lecture, or a classical concert.

BUILT-IN MICROPHONE

The BU-51H has a convenient, built-in microphone with adjustable settings.

POSITIONAL INFORMATION

The BU-51H provides PAN/TILT/ZOOM/FOCUS position information.

NIGHT MODE

The BU-51H now include "night mode". The shutter speed is slowed down to a minimum of 1/4(60i,30F) or 1/3(50i,25F,24F) allowing frame accumulation that elevates camera sensitivity.

NON-PROPRIETARY PROTOCOL

As the control protocol is non-proprietary and open to the public, a user or system integrator can provide their own control system or contract with a third party provider.

VARIETY OF OUTPUTS

The camera outputs an uncompressed HD-SDI (or SD-SDI) signal. The HD-SDI signal and an SD Composite signal (NTSC or PAL)* can be output simultaneously. The SD signal can be used for monitoring. In addition, the BU-51H features GENLOCK for video synchronization.

*Please request NTSC or PAL format at time of purchase



Photos are simulated

BU-51H System Configuration Examples

For Short Distance Control

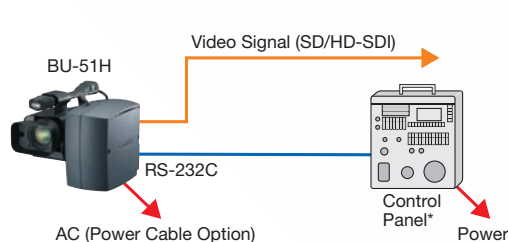

For Long Distance Control

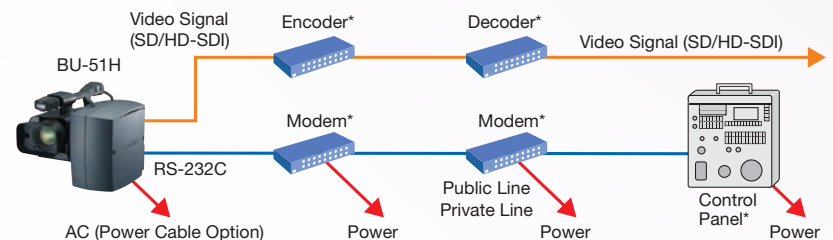

*Optional items to be supplied from third party vendors.

SPECIFICATIONS

Pan-Tilt Section

	BU-47H	BU-51H
Operation condition	Outdoor	Indoor
Operational angle	Panning: 340°, Tilting: +30° ~ -50°	Panning: 300°, Tilting: +40° ~ -40°
Operating speed	Panning: 0.5-25°/s, Tilting 0.3-20°/s	Panning: 0.3-30°/s, Tilting 0.3-30°/s
Repeatability	Within ±10°	Within ±10°
Connector Receptacle	DC terminal, Control (RS-422), SDI out, SD composite, Genlock, Aux out	AC Inlet, Control (RS-232C), AUX out (includes position information)
Video output	HD-SDI (Embedded audio) output BNC1 Line (receptacle section) SD composite (NTSC/PAL) output BNC1 Line (receptacle section)	HD-SDI, HD analog component, SD composite
GENLOCK input	BNC 1 Line (receptacle section) (3 value/BB)	BNC 1 Line (3 value/BB)
Noise	NC55 below	NC30 below (when operated in 25°/s)
Power source	DC10.5-15V 80W	AC100-240V 50/60Hz 60W
Operating temperature	Ambient -15-40°C / ~90% (Without being dew condensation)	Ambient 0-40°C / ~90% (Without being dew condensation)
Microphone	Input: pedestal section	Output: SDI (Embedded audio), analog (stereo)
Size (Include Camera&Lens)	386(W) x 390(H) x 337(D) mm	350(W) x 275(H) x 305(D) mm
Mass (Include Camera&Lens)	Approx. 17kg	Approx. 11kg
Wiper	Built-in Wiper	—
Washer	Connector on Pedestal Section for Third Party Washer Unit	—
Dustproof/waterproof efficiency	IP45	—
Wind Velocity-Resistance	0-25m/s Normal operation 25-35m/s Operation possible 35-60m/s Non destruction	—

Camera & Lens Section

	BU-47H	BU-51H
Pick-UP device	1/3" HD 3CMOS, total of approx. 2.37 megapixels per CMOS	1/3" HD 3CCD, total of approx. 1.67 megapixels per CCD
Range of Focal Length	4.1-73.8mm (6.2-111mm w/1.5x)	4.5-90mm(9-180mm w/2x)
Zoom Ratio	F1.6-2.8 (2/3" conversion: 7.4-134mm, 11.1-201mm w/1.5x)	F1.6-3.5 (2/3" conversion: 8.25-165mm, 16.5-330mm w/2x)
Zoom Ratio	18x Optical zoom (1.5x digital extender)	20x Optical zoom (2x digital extender)
Focusing system	AUTO, Manual	AUTO, Manual
IRIS	AUTO, Manual	AUTO, Manual
Frame rate and Shutter speed	BU-47H 1AM / BU-51H 1A* BU-47H 2AM / BU-51H 2A* Frame Rate: 60i Shutter Speed: 1/4, 1/15, 1/60, 1/100, 1/1000 Frame Rate: 50i Shutter Speed: 1/3, 1/12, 1/50, 1/100, 1/1000	Frame Rate: 60i Shutter Speed: 1/4, 1/15, 1/60, 1/100, 1/1000 Frame Rate: 50i Shutter Speed: 1/3, 1/12, 1/50, 1/100, 1/1000
Gain	AUTO, 0dB, 6dB, 12dB, 18dB, 33dB	AUTO, 0dB, 6dB, 12dB, 18dB, 36dB
White balance	AUTO, Set	AUTO, Set
CCU adjustment	White balance, Master pedestal, R-gain, B-gain, G-gain, Hue, Master black(R/G/B), Set up level, Gamma, Knee, Sharpness, Knee aperture, Skin detail, Color matrix, Horizontal detail frequency	Master pedestal, R-gain and B-gain
GENLOCK Phase adjustment	Adjustment range approx. ±0.4H	Adjustment range approx. ±0.4H
Image Stabilizer	Optical Shift method	Optical Shift method
Optical Filter	CLEAR, 1/4ND, 1/16ND, 1/64ND	—
Shooting Mode	AUTO, Manual	AUTO, Manual, Night

* Suffix 1AM/1A corresponds to NTSC, 2AM/2A corresponds to PAL

DIMENSIONS

BU-47H

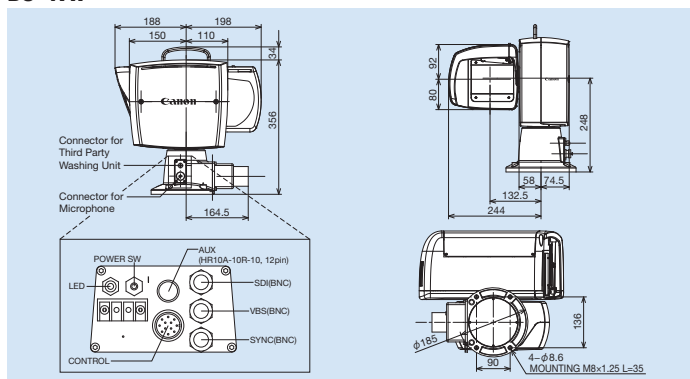

BU-51H

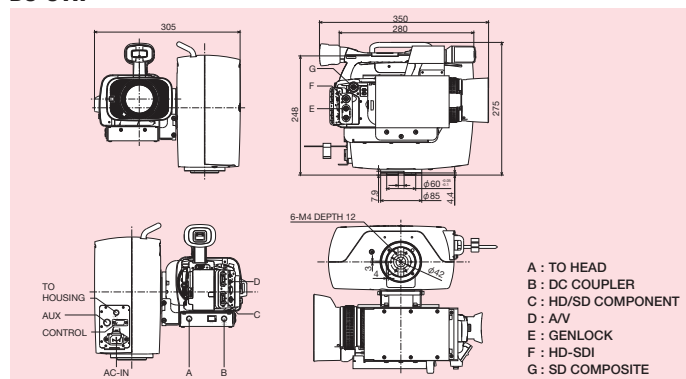

1-800-OK-CANON
pro.usa.canon.com

Canon U.S.A., Inc.
One Canon Park
Melville, NY 11747 U.S.A.

Canon
image*ANYWARE*

©2013 Canon U.S.A., Inc. All rights reserved. All images and effects simulated. Specifications and availability are subject to change without notice. Products not shown to scale. Weight and dimensions are approximate. Not responsible for typographical errors. Canon is a registered trademark of Canon Inc. in the United States and may also be a registered trademark or trademark in other countries.

PRINTED IN U.S.A.